

The Adams & Westlake Company

New York

CHICAGO

Philadelphia

Railway Motor Car Lamps

These lamps are designed to meet the requirements of the State Public Utilities Commission of Illinois.

The State Public Utilities Commission of Illinois requires that:

2. "Every railroad motor car, when operated between sunset and sunrise shall be equipped with a visible signal on the front end of each such car, in the form of a fixed or portable headlight which can be readily seen for a distance of not less than three hundred (300) feet."

5. "This rule shall be in force and effect on and after July 1, 1917."

See rules two and five of General Order No. 40, dated March 7, 1917, as quoted above.

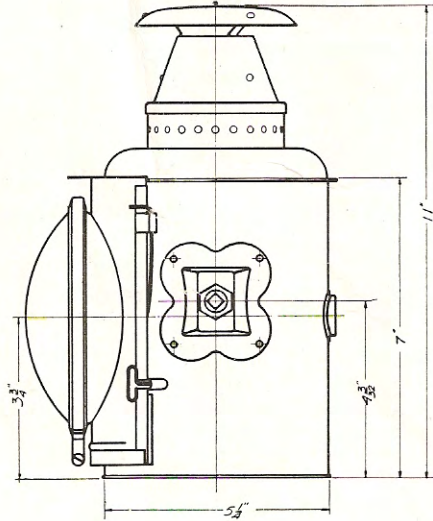

The No. 341 Lamp has Adlake
Balance Draught Ventilation,
 $5\frac{3}{8}$ inch Semaphore Lens —
Outside Wick Raiser.

This lamp can be furnished with
two lenses.

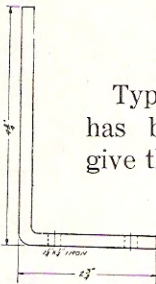

Type "L" Bracket
has been found to
give the best results.

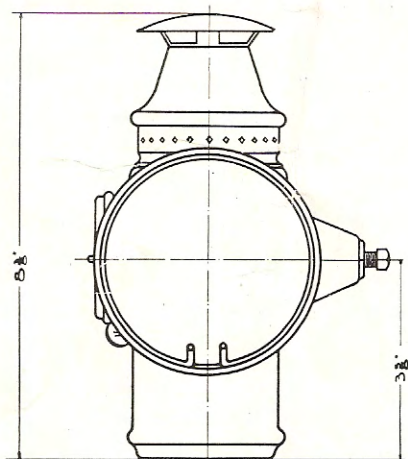

The No. 332 Lamp has Adlake
Balance Draught Ventilation,
4 inch Semaphore Lens —
Outside Wick Raiser.

This lamp can be furnished with
two lenses.

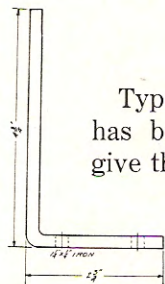

Type "L" Bracket
has been found to
give the best results.